

YG-DCO-032-5.3.3E(B)

Yorkshire Green Energy Enablement (GREEN) Project

Volume 5

Document 5.3.3E(B) ES Chapter 3 Appendix 3E - Outline Soil
Management Plan

Final Issue AB

~~November 2022~~ April 2023

Planning Inspectorate Reference: EN020024

Infrastructure Planning (Applications: Prescribed Forms and
Procedure) Regulations 2009 Regulation 5(2)(a)

nationalgrid

Page intentionally blank

Contents

1.	Outline Soil Management Plan	1
1.1	Introduction	1
1.2	Glossary of Terms	2
1.3	Roles and Responsibilities	3
	Project Manager	3
	Site Manager/Engineer	3
	Safety, Health, and Environment Manager/Advisor	4
	Site Foreman	4
	The Land Officer	4
	Environmental Clerk of Works	5
	Technical Specialist Advisor	5
1.4	Limitations of use of the Outline SMP	5
1.5	Review and update of the Outline SMP	6
1.6	Soil Resource	6
	Soils with low risk of erosion	6
	Soils with moderate risk of erosion	7
	Soils with high risk of erosion	7
1.7	Good Practice Mitigation	7
	General principles of soil handling	7
	Stop conditions	8
	Soil Preparation	11
	Soil stripping	12
	Creation of soil stockpiles	15
	Drainage	18
	Restoration	18
	Aftercare	21
1.8	Biosecurity	21
1.9	Ground Protection	22
1.10	Bespoke Mitigation Measures	23
	Monitoring Schedule	23
	Management of surplus soils	24

	Table 1.1 - Testing for Soil Moisture State	10
	Table 1.2 - Testing for Soil Consistency	10
	Table 1.3 - Record keeping and monitoring during the construction phase.	23

Graphic 1.1 -Stripping with excavators and dump trucks: removal of topsoil from a strip. Reproduced from MAFF, 2000.	14
Graphic 1.2 -Stripping with excavators and dump trucks: removal of subsoil from a strip. Reproduced from MAFF, 2000.	14
Graphic 1.3 - Soil storage mound construction with excavators and dump trucks. Reproduced from MAFF, 2000.	17
Graphic 1.4 - Excavation of soil storage mound with excavators and dump trucks. Reproduced from MAFF, 2000.	19

Version history

Date	Version	Status	Description/changes
01/11/2022	A	Final	First Issue
<u>26/04/2023</u>	<u>B</u>	<u>Final</u>	<u>Amendment to wording in paragraphs 1.1.4 and 1.5.1</u>

Page intentionally blank

1. Outline Soil Management Plan

1.1 Introduction

- 1.1.1 This Outline Soil Management Plan (Outline SMP) sets out principles and procedures for good practice and bespoke mitigation measures in soil handling, storage and reinstatement to be used for the Yorkshire Green Energy Enablement (GREEN) Project (“the Project” or “Yorkshire GREEN”). This Outline SMP describes the principles that the appointed Contractor will follow to minimise adverse effects on the nature and quality of the soil and will be implemented through Development Consent Order (DCO) Requirement 5 (**Volume 3, Document 3.1**).
- 1.1.2 To secure effective delivery of the Outline SMP, the Contractor must implement it through site-specific soil management method statements (or similar) for the construction phase as part of soil and aftercare management plan (implemented through DCO Requirement 6). The works must also be monitored to audit compliance with the Outline SMP (and location-specific construction method statements); and to allow ongoing advice on soil handling to be provided. The Outline SMP is based upon guidance such as the Department for Environment, Food and Rural Affairs (Defra’s) Construction Code of Practice for the Sustainable Use of Soils on Construction Sites¹; the Ministry of Agriculture, Fisheries and Food’s (MAFF’s) Good Practice Guide for Handling Soils², Institute for Quarrying (IoQ) Good Practice Guide for Handling Soils in Mineral Workings³, National Grid Electricity Transmission plc (“National Grid”)’s ‘Construction Best Practice for Underground Cable Installation’⁴, and the consultant’s experience. It is noted that although the IoQ guide is titled for use in mineral workings, it is applicable to all infrastructure projects, particularly those where large volumes of soil are to be stripped, stored, and reinstated, such as linear infrastructure projects.
- 1.1.3 The Outline SMP assumes that all mitigation measures pertaining to protected species and other environmental issues are in place, such that the soil stripping, storage and reinstatement operations can proceed.
- 1.1.4 ~~The Outline SMP sets out the principles of soil management. Further detail based on construction methodology and environmental information will be provided in the Detailed Soil and Aftercare Management Plan prior to commencement of construction operations which The Outline SMP is considered to be a ‘live document’ to be updated as further information becomes available. The Outline SMP will be revised (to the Detailed Soil and Aftercare Management Plan) prior to commencement of construction operations~~

¹ DEFRA (2009) Construction Code of Practice for the Sustainable Use of Soils on Construction Sites. (Online) Available at: https://www.gov.uk/government/uploads/system/uploads/attachment_data/file/69308/pb13298-code-of-practice-090910.pdf (Accessed July 2022).

² MAFF (2000). Good Practice Guide for Handling Soils. (Online) Available at: <https://webarchive.nationalarchives.gov.uk/ukgwa/20090317221756/http://www.defra.gov.uk/farm/environment/land-use/soilguid/index.htm> (Accessed July 2022)

³ Institute of Quarrying (2021) Good Practice Guide for Handling Soils in Mineral Workings. (Online) (Accessed July 2022)

⁴ National Grid (2021). Construction best practice for underground cable installation (Version 1). (Online) (Accessed July 2022)

and will be informed by information provided through the detailed pre-construction soil surveys secured through DCO requirement 6. These pre-commencement soil and Agricultural Land Classification (ALC) surveys will incorporate all land which will be subject to direct disturbance, and which has yet to be subject to a detailed soil survey as part of the Project. Not only will this data aid in the production and implementation of the Detailed SMP, but it will also provide baseline land quality data for the reinstatement of land within the proposed working area where soil is to be stripped within the Order Limits.

- 1.1.5 It is noted that to inform the ES, detailed soil and ALC surveys have been conducted by Wardell Armstrong (WA) in areas of proposed permanent development (the proposed Cable Sealing End Compounds (CESC) and substations and for some of the new haul roads and bellmouths).

1.2 Glossary of Terms

- 1.2.1 The following definitions are provided to aid understanding of the Outline SMP.

- **Field Capacity** - The condition in which the soil is saturated with water and any water from rainfall will infiltrate quickly under the force of gravity or create waterlogging.
- **Soil Ped** - Soil peds are natural, relatively permanent aggregates of soil particles, separated from each other by voids or natural surfaces of weakness; and which persist through cycles of wetting and drying.
- **Plastic** - A plastic material can be moulded into a shape and the material will retain that shape. Where practicable, soil should not be handled when in a plastic state (considered to be too wet) and if handling is unavoidable additional measures must be in place.
- **Lower Plastic Limit** - The lower plastic limit is defined as the moisture content at which soil begins to behave as a plastic material. If the moisture content is below the lower plastic limit, it is considered to behave as a solid, or a non-plastic material.
- **Statement of Physical Characteristics Report** - A report normally produced in conjunction with an agricultural land classification survey, which describes the different soil profiles in detail, allowing the restoration of the site to be judged against this benchmark⁵.
- **Tilth** - Soil tilth is its physical condition, especially in relation to its suitability for planting or growing a crop. Soil with good tilth has large pore spaces for air infiltration and water movement. Roots only grow where the soil tilth allows for adequate levels of soil oxygen. Such soil also holds a reasonable supply of water and nutrients.
- **Plant evapotranspiration** - the process by which water is transferred from the land to the atmosphere by evaporation from the soil and other surfaces and by transpiration from plants.

⁵ Defra (2004). Defra guidance for successful reclamation of mineral and waste sites. Defra; London.

1.3 Roles and Responsibilities

- 1.3.1 The effective implementation of the Outline SMP requires that roles and responsibilities are clearly defined and understood. Specific job titles, roles and responsibilities will be defined by the Contractor in the location specific construction management plans; however, the roles and responsibilities are expected to be similar to those described below, as detailed in the **Code of Construction Practice (CoCP)** presented in **Appendix 5.3.3.B, Volume 5, Document 5.3.3B**. The appointed Contractor will be responsible for the preparation and subsequent implementation of site-specific soil management method statements and Risk Assessment Method Statements (RAMS) (or similar) for the construction phase. These will be appended to the Outline SMP.
- 1.3.2 All site staff will be sufficiently experienced and trained to perform all required tasks. The training and awareness are to be ensured according to the procedures and tools described in the **CoCP, Volume 5, Document 5.3.3B**. The contractor must carry out toolbox talks with all personnel involved in the groundworks, communicating the principles of good practice in soil management and its goals.

Project Manager

- 1.3.3 The Project Manager is responsible for:
- coordinating the delivery of all elements of the Project including ensuring conformance with the **CoCP, Volume 5, Document 5.3.3B** and other management plans (including SMP), as well as any incident investigation required;
 - facilitating the dissemination of generic environmental requirements to the project team;
 - overseeing the implementation and review of environmental procedures throughout the project;
 - monitoring the environmental performance of the Project through maintaining an overview of incidents, inspections and audits; and
 - ensuring that environmental considerations form an integral part of design and implementation of the works and to include environmental reviews as part of regular project meetings.

Site Manager/Engineer

- 1.3.4 The Site Manager/Engineer, working with the Project Manager is responsible for:
- understanding and implementing all environmental procedures as identified in the **CoCP, Volume 5, Document 5.3.3B** and other management plans (including SMP), and ensuring that site operations function in compliance;
 - reviewing risk assessments and method statements (RAMS) and/or Environment Method Statements (EMS) submitted by the Contractor prior to beginning new works activities;
 - monitoring of Contractor compliance with plans and procedures; and
 - conducting regular site inspections.

Safety, Health, and Environment Manager/Advisor

1.3.5 The SHE Manager/Advisor is responsible for:

- providing site inductions and toolbox talks on safety, health and environmental matters and sensitivities to the appropriate staff prior to works being undertaken;
- assisting the Project Manager and Site Manager/Engineer in reviewing and approving RAMS and/or EMSs;
- ensuring the RAMS/EMSs are implemented, ensuring compliance with procedures and legislation;
- providing technical advice on the implementation of the **CoCP, Volume 5, Document 5.3.3B**, and other management plans, including changes to legislative requirements and best practice; and
- undertaking regular site inspections/walkovers to ensure construction practice is compliant with best working practices and approved RAMS/EMS.

Site Foreman

1.3.6 Responsible to the Construction Manager for:

- implementing the site-specific construction soil management method statements to manage soil handling and storage on site to ensure the sustainable use of the soil resource;
- ensuring daily records of weather conditions, stoppages and soil plasticity (moisture) testing are made and kept;
- ensuring that works are carried out safely, under correct conditions and in compliance with wider environmental requirements; and
- ensuring that the protection of services is maintained during the soil handling works.

The Land Officer

1.3.7 The Land Officer may be supported by an Agricultural Liaison Officer (ALO) (or similar). For the Project a combination of NGETs ALO and the contractors ALO will provide information and communications to local landowners and those with land-related interests regarding daily construction activities.

1.3.8 The Land Officer /ALO will ensure that the specifications of the Outline SMP and site-specific construction method statements/soil management plans are implemented. It is envisaged that the ALO will have sufficient soil science experience or that they will work in cooperation with a Technical Specialist Advisor (TSA) with soil science capability. This will ensure awareness of any potential issues arising, which may include potential reinstatement issues which may result in unavoidable crop losses and may culminate in increased compensation claims.

1.3.9 The main duties of the Land Officer/ALO will comprise, but will not be limited to:

- liaison between the Contractor, landowners, Project and all party's Land Officers;
- assessment of the soil condition during and after the works using tactile and visual methods;

- assessing compliance of the work on site with the Outline SMP and site specific detailed SMPs once finalised;
- signing off the quality of restoration to allow for the commencement of the aftercare;
- ensuring the adequacy of the Detailed Aftercare Programme (DAC) and its annual updates (if required and should form part of the detailed SMP);
- soil sampling and production of annual aftercare reports; and
- signing off completion of the DAC.

Environmental Clerk of Works

- 1.3.10 An Environmental Clerk of Works (ECoW) will be appointed for the duration of the construction. The ECoW will ensure the implementation of, and compliance with, the provisions of the **CoCP, Volume 5, Document 5.3.3B** and other management plans (including the SMP).
- 1.3.11 The ECoW could be from a company who provide a general Clerk of Works who can liaise with a team of specialists in specific environmental subjects, such as soils and agriculture, where required throughout construction, or a suitably qualified individual. The ECoW is responsible for inspections/audits of the Contractor's work site to ensure compliance with environmental standards and requirements.

Technical Specialist Advisor

- 1.3.12 In relation to the SMP the main duties of the Technical Specialist Advisor (TSA) will comprise, but will not be limited to:
- providing advice with respect to construction activities and their interface with respective technical areas of expertise;
 - undertaking any necessary pre-construction surveys and supervising the implementation of specific mitigation measures, where required;
 - undertaking any required monitoring related to their specialism;
 - providing reports and maintaining contact with relevant stakeholders, as required; and
 - providing specific advice with respect to any issues that arise.

1.4 Limitations of use of the Outline SMP

- 1.4.1 The Outline SMP should be read in conjunction with Project Documents, including **Appendix 3.B CoCP (Volume 5, Document 5.3.3B)** and other plans and protocols referred to therein. The Outline SMP does not provide safe working guidance and should be read in conjunction with the relevant detailed construction method statements and risk assessments prepared by the appointed Contractor. Attention is drawn to the responsibilities arising from the Construction (Design and Management) Regulations (CDM) 2015⁶.

⁶ UK Government (2015). Construction (Design and Management) Regulations (CDM), 2015. (Online) <http://www.legislation.gov.uk/ukxi/2015/51/contents/made> (Accessed July 2022).

- 1.4.2 Persons involved in the handling of soils and overburden or similar, and in the construction or removal of mounds or tips, must comply with the Health and Safety at Work Etc. Act 1974 and its relevant statutory provisions, in particular, those aspects which relate to the construction and removal of tips, mounds and similar structures⁷. This requirement takes precedence over any suggested practice presented in this document. The user of the Outline SMP is solely responsible for all liabilities that might arise. No liabilities are accepted for any losses of any kind arising from the use of this Outline SMP.

1.5 Review and update of the Outline SMP

~~4.5.1—The Outline SMP sets out the principles of soil management, and further detail based on construction methodology and environmental information will be detailed within the Soil and Aftercare Management Plan, required secured through Requirement 6(1)(a). As discussed above, the Outline SMP is considered to be a ‘live document’ as changes are likely to be required to the Outline SMP throughout the construction phase of the Project for one or more of the following reasons:~~

- ~~• a new environmental sensitivity is identified as a consequence of changing environmental conditions, or following additional survey work;~~
- ~~• changes are introduced to construction methodology or programming.~~

~~4.5.2~~1.5.1 The Outline SMP will be reviewed prior to commencement of construction to consider additional site-specific soils data compiled via the pre-commencement soil surveys (**Section 1.1**).

1.6 Soil Resource

- 1.6.1 The erodibility of a soil (susceptibility to damage and loss) influences the level of mitigation required to protect it and the measures to be put in place through the Outline SMP and site-specific construction method statements.
- 1.6.2 Soil erodibility is based on the Soil Survey of England and Wales mapped soil associations and the erosion risk from Cranfield et al, as described in **Chapter 11: Agriculture and Soils, Volume 5, Document 5.2.11**. Detailed pre-construction soil surveys should provide higher resolution baseline data from which site-specific soil management plans can consider soil erodibility.
- 1.6.3 Although no peat or peaty soils has been identified within the data collection process, if any peat is found a best effort should be made to leave it in situ.

Soils with low risk of erosion

- 1.6.4 Good practice (embedded mitigation) measures following those recommended in Defra’s Construction Code of Practice for the Sustainable Use of Soils on Construction Sites¹; MAFF’s Good Practice Guide for Handling Soils²; and Institute for Quarrying Good Practice Guide for Handling Soils in Mineral Workings³, will provide appropriate protection to these soils as they are generally more resistant to damage and loss.

⁷ UK Government (1974). Health and Safety at Work Act, 1974. (Online) <http://www.legislation.gov.uk/ukpga/1974/37/contents> (Accessed July 2022).

Soils with moderate risk of erosion

- 1.6.5 Good practice (embedded mitigation) measures will mostly provide appropriate protection to these soils, however damage is likely to occur if worked in less-than-ideal conditions, for example when the soils are wet. Therefore, on a location-by-location basis, depending upon factors such as physical soil properties, local topography or weather conditions, bespoke mitigation measures may be required (detailed in **Section 1.10**). The soils should be given appropriate consideration because of their importance for agricultural production.

Soils with high risk of erosion

- 1.6.6 Development on those soils should be avoided if possible, however where this is not possible, they require special consideration and careful planning of construction methods, i.e. bespoke mitigation measures, in order to preserve their structure and function (see **Section 1.10**).
- 1.6.7 The baseline studies presented in **Chapter 11 (Volume 5, Document 5.2.11)** have identified soils with a high risk of erosion within the boundary of the Project. The extent of their coverage is c. 10.1 ha (1.9 %) of the Study area and 1.7 ha (10.3%) of the proposed working area, due to the presence of the Newport 1 (551d) and Everingham (821a) soil associations.

1.7 Good Practice Mitigation

General principles of soil handling

- 1.7.1 The main threats to soil resources at construction sites are trafficking of vehicles/plant and incorrect handling, which can cause damage to soil structure through compaction and smearing (both effects are sometimes referred to as deformation). These effects compromise the ability of the soil to perform its functions, such as providing adequate amounts of water, air and nutrients to plant roots. The risk of compaction and smearing increases with soil wetness.
- 1.7.2 To minimise the risk of damage to soil structure, the following main rules must be observed during all soil handling tasks:
- no trafficking/driving of vehicles/plant or materials storage to occur outside designated areas (access roads, construction working areas and material storage areas within the Order Limits);
 - no trafficking/driving of vehicles/plant on reinstated soil (topsoil or subsoil);
 - where practicable only direct movement of soil from donor to receptor areas (no triple handling and/or ad hoc storage);
 - no soil handling to be carried out when the soil moisture content is above the lower plastic limit (see **Table 1.1** and **Table 1.2**: Soil Condition infield test);
 - soils should only be moved under the driest practicable conditions and this must take account of prevailing weather conditions (see rainfall “stop” criteria in Stop conditions from paragraph 1.7.5);
 - no mixing of topsoil with subsoil, or of soil with other materials;
 - soil only to be stored in designated soil storage areas;

- where practicable plant and machinery to work only when ground or soil surface conditions enable their maximum operating efficiency, to be determined by the Site Foreman;
 - all plant and machinery must always be maintained in a safe and efficient working condition, which should be monitored by the Site Foreman following H&S procedures; and
 - daily records of operations undertaken, and site and soil conditions should be maintained (see **Section 1.5** for the summary of monitoring and record keeping schedule).
- 1.7.3 Low ground pressure models (LGP models) and tracked vehicles should be used where possible. This will greatly minimise the extent and/or intensity of the soil loosening required after construction and/or site aftercare. Consequently, it will reduce the costs and potential delays due to the need for additional soil cultivation.
- 1.7.4 The location-specific method statements must be defined based on the results of detailed site-specific soil survey which have been or will be conducted on all land which will be subject to direct disturbance due to the Project (see **Section 1.1**). The survey results should be used to specify in detail:
- the ‘before’ statement of physical characteristic of the soil to be disturbed;
 - where bespoke mitigation measures are required, and what these bespoke measure entail;
 - the depth and properties of topsoil; and
 - the depth of subsoil and presence of any distinct soil horizons.

Stop conditions

Adverse weather

- 1.7.5 In certain weather conditions, the handling of topsoil and subsoil must be effectively managed to prevent damage. The appointed contractor should decide whether all work or certain activities should be stopped in the following circumstances:
- in drizzle and/or intermittent light rain, handling can continue for up to four hours unless the soils are already in a plastic state (see from paragraph 1.7.10: Soil Condition);
 - if there is heavy rain (e.g. heavy showers, slow moving depressions), handling should stopped immediately;
 - if there is sustained heavy rainfall of more than 10 mm in 24 hours, soil handling should be suspended and not restarted until the ground has had at least a full day to dry, or the soil is below the lower plastic limit (as described from paragraph 1.7.10: Soil Condition **Table 1.1** and **Table 1.2**); and
 - soil shall not be handled or trafficked over/driven on immediately after a heavy rainfall (or snow/hail) in a waterlogged condition, or when there are standing pools of water on the soil surface.
- 1.7.6 If the works are interrupted by a rainfall event, soil stripping should be suspended; and where the soil profile has already been disturbed, the works should be completed to the base level in that location.

- 1.7.7 Before recommencing work, soil moisture content should be tested, as described from paragraph 1.7.10: Soil Condition **Table 1.1** and **Table 1.2**, and only recommence if soil moisture is below the lower plastic limit. The weather forecast must also be checked and works only recommenced if there is no rain forecast for at least a day, regardless of soil moisture condition.
- 1.7.8 Additionally, soil should not be handled or trafficked over/driven on when the ground is frozen or covered by snow.
- 1.7.9 The above criteria should be clearly understood by all personnel working on site.

Soil conditions

- 1.7.10 Irrespective of the weather, where practicable soils should not be handled when in a plastic state (when moisture content exceeds their lower plastic limit); and it is best practice that soil should be dry when handled. This section and **Table 1.1** and **Table 1.2**, set out the methodology for determining whether soils are in a state where they can be handled.
- 1.7.11 A project-wide seasonal constraint to the construction programme is not recommended as this may not be achievable in practice. The soil types identified within the Project (which comprise loams and clay loams, described in **Chapter 11: Agriculture and Soils, Volume 5, Document 5.2.11**) combined with the moderately high excess winter rainfall in the Yorkshire Region, mean that soil handling should be restricted to the drier periods of the year when the soils are below their plastic limit wherever possible (See paragraph 1.7.10: Soil Condition **Table 1.1** and **Table 1.2**). However, due to the scale of the Project, it is understood that some soil handling when the soils are wet (in a plastic state) may be necessary.
- 1.7.12 If the soil is excavated and placed in stockpiles when wet (above the plastic limit), they are easily compacted by the machinery handling them, or by the weight of the soil above in the stockpile, and additional measures will be required to minimise damage to soil structure as far as practicable. Such additional measures may include, but are not limited to, reducing stockpile heights to low single tiered mounds, reducing the number of times the soil is handled during wet, using equipment that is less detrimental to soil structure (such as an excavator and dump truck). As well as this damage to soil structure, when soils within a stockpile are compacted, the core of the stockpile remains anaerobic throughout the storage period. This damage results in the soil being very difficult to handle and re-spread at the time of reinstatement (i.e. it will not be in a friable state and will not break down into a suitable tilth). In this case, in order to achieve the required standard of reinstatement, a period of drying and appropriate additional cultivation is required (to repair soil structure and re-aerate the soil) to ensure the soil is acceptable for planting. Should wet handling of soils be necessary, appropriate soil handling, drying and cultivation methodologies will be set out in the Detailed Soil and Aftercare Management Plan and in site-specific construction method statements, as required.
- 1.7.13 For arable land, the period where the soil conditions will generally be the driest, and most optimum for soil handling operations, typically occur in the summer following the crop harvest, when the plant evapotranspiration will have dried the soil. However, this does not exclude soil handling at other times of the year.
- 1.7.14 Once the placement of soils into each stockpile has been completed, providing the soil was not in a plastic state, rainfall and soil moisture conditions are of lesser importance, providing they do not lead to significant environmental impacts, such as erosion and

discharges of sediment laden water from the stockpiles to drainage ditches and other watercourses.

Field testing of soil conditions

- 1.7.15 Prior to the start or recommencement of soil handling operations, the following two stage methodology, comprising a moisture state test and a consistency test, has been recognised by Natural England as an acceptable and valid approach; as it is considered to be less open to interpretation and easier to conduct than use of consistency testing (**Table 1.2**) alone.
- 1.7.16 At least five points per area to be worked on a given day should be sampled (a minimum of one point per 50 m of the length of the working area, or two samples per hectare). The sample should be a composite of at least five subsamples from around each sample point. Samples of both topsoil and subsoil should be taken and sampled separately.

Soil moisture state

- 1.7.17 The samples should first be tested for soil moisture state as per the methodology in **Table 1.1**.

Table 1.1 - Testing for Soil Moisture State

Test	Handling allowed?
If soil sample is wet, films of water are visible on the surfaces of grains and aggregates; or if soil sample readily deforms into a cohesive 'ball' when squeezed	Soils should not be handled (or if handling cannot be avoided additional measures be required as per paragraph 1.7.12).
Soil peds break up/crumble readily when squeezed in the hand. Sample does not form a cohesive ball.	Soils can be handled.
If the sample is moist, there is a slight dampness when squeezed between the fingers, but it does not significantly change colour (darken) on further wetting.	No handling by dozers but may be handled by excavators if the consistency test is passed.
Sample is dry and brittle. Sample looks dry and changes colour (darkens) on wetting.	Soils can be handled if the consistency test is passed.

Consistency

- 1.7.18 Where required as per **Table 1.1**, samples should be further tested for consistency as per the methodology in **Table 1.2**.

Table 1.2 - Testing for Soil Consistency

STEP A:	
Attempt to roll sample into a ball by hand	
It is impossible because the soil is too hard (dry).	Soils can be handled.

STEP A:**Attempt to roll sample into a ball by hand**

It is impossible because the soil is too loose (dry).	Soils can be handled.
It is impossible because the soil is too loose (wet).	Soils should not be handled (or if handling cannot be avoided additional measures be required as per paragraph 1.7.12).
It is possible to roll the sample into a ball by hand.	See Step B

STEP B:**Attempt to roll the ball into a thread of 3 mm diameter on a flat non-adhesive surface using light pressure from the flat of a hand**

It is impossible as the soil crumbles or disintegrates.	Soils can be handled.
It is possible to roll a 3 mm diameter thread.	Soils should not be handled (or if handling cannot be avoided additional measures be required as per paragraph 1.7.12).

1.7.19 The final decision on whether soil handling can commence will be made by the Site Foreman and be based upon at least 80% of samples passing the particular test.

1.7.20 The above criteria should be clearly understood by all personnel working on site.

Soil Preparation

1.7.21 Mark and signpost the undisturbed areas where no construction activities or vehicle trafficking over/driving on is to take place per detailed Works Plans and construction method statements (to be prepared post-consent by the Contractor) which will be included in the soil and aftercare management plan and secured by DCO Requirement 6. Any trees, hedgerows or valuable habitats which are to be retained should be marked out with barrier tape; and subsequently protected and managed.

1.7.22 As per the requirements of detailed works plans and construction method statements (to be prepared post-consent by the Contractor), any underground services crossing the area of soil stripping are to be surveyed and their depth and position clearly marked to ensure they are not impacted by the stripping works. After stripping, to ensure the integrity of the service infrastructure is maintained, the service location may require fencing off; or if the area over the service is to be trafficked additional protection or mitigation may be required.

1.7.23 Mark each soil storage area for different types of topsoil, subsoil and mineral substrate. In some locations, the excavated soil profile may contain more than one distinct subsoil horizon (layer). Where this occurs, due to the different properties of the different horizons, they must be excavated and stored separately. Locations requiring the storage of more than one subsoil horizon should be identified through review of the soil survey records and specified in the location-specific construction method statements.

- 1.7.24 At designated crossings (specified in the location-specific construction method statements) a recommended 2 m width of topsoil will be left unstripped at either side of the ditch/watercourse to act as a filter for water run-off.
- 1.7.25 To reduce the likelihood of anaerobic conditions developing within the topsoil stockpile, prior to the soil strip commencing the topsoil surface should either be bare, under stubble, or have only short surface vegetation. To achieve short surface vegetation (for example in areas of permanent pasture or meadow land), if not already done so prior to the land being handed over to the Project, the area should be mown or strimmed. Cuttings should be lifted and disposed of off-site to a suitably licenced facility with reuse and recycling favoured over disposal (e.g. recycling via a local composting facility). Cuttings must **not** be added to or mixed with the stripped soil, as the presence of excessive amounts of plant material in the stockpile will be detrimental to its quality due to its putrefaction (rotting) in anaerobic conditions. Alternatively, the vegetation may be killed off by application of a suitable, Environment Agency approved, non-residual herbicide applied not less than two weeks prior to commencement of soil stripping operations at the location. Herbicide may only be used with the consent of the landowner and subject to the conditions/restrictions within the contract.

Soil stripping

- 1.7.26 Topsoil can be stored on either topsoil (of the same type) or on subsoil. Subsoil can ONLY be stored on subsoil and therefore the topsoil must be stripped from subsoil storage areas in advance of subsoil stripping.
- 1.7.27 The stripping method should follow one of the suggested methods as described in the MAFF's Good Practice Guide to Handling Soils² and its update the IoQ's Good Practice Guide for Handling Soils in Mineral Workings³. As stated above, topsoils and subsoils will be stored separately.
- 1.7.28 Prior to construction, the appointed Contractor will engage a suitably experienced archaeologist(s) to prepare an Archaeological Mitigation Strategy (refer to the **Archaeological Written Scheme of Investigation, Volume 5, Document 5.3.3C**) to fully describe the archaeological mitigation measures to be implemented. These may include 'Strip, Map and Sample' or Detailed Archaeological Excavation works to be undertaken in advance of main construction activities. Should the need for archaeological mitigation works be identified, in these areas the soils will be stripped as per the conditions required and agreed in the Archaeological Mitigation Strategy. The soil strip will be subject to the mitigation measures set out in this document with respect to the management and protection of soil resources; however, a **toothless bucket** may be employed to prevent damage to the underlying archaeology. It is expected that (in most locations) the excavated soil will be stored on the margin of the working area and that the use of dumper trucks will not be required.
- 1.7.29 Where soils are to be stored away from the excavation area, a minimum of two excavators and one transport vehicle will be required for soil stripping operations. One excavator will be required to undertake the soil stripping and the other to form the soil stockpiles. The excavator undertaking the soil stripping should be fitted with a toothed bucket, except in the areas of known archaeological significance or high archaeological potential (see above), where a toothless bucket should be employed to prevent damage to the underlying archaeology. The method, if correctly carried out, should avoid severe compaction as soil trafficking is minimised. The concept of this method is shown in **Graphic 1.1** and **Graphic 1.2**.

- 1.7.30 The size of the earthmoving plant to be used should be tailored to the size of the area to be stripped and the space available within the working area. The use of a long reach excavator, which will minimise the need for movement across the soil surface, and the use of tracked vehicles or vehicles with a low ground bearing pressure is recommended to further reduce soil compaction.

Graphic 1.1 -Stripping with excavators and dump trucks: removal of topsoil from a strip.
 Reproduced from MAFF, 2000².

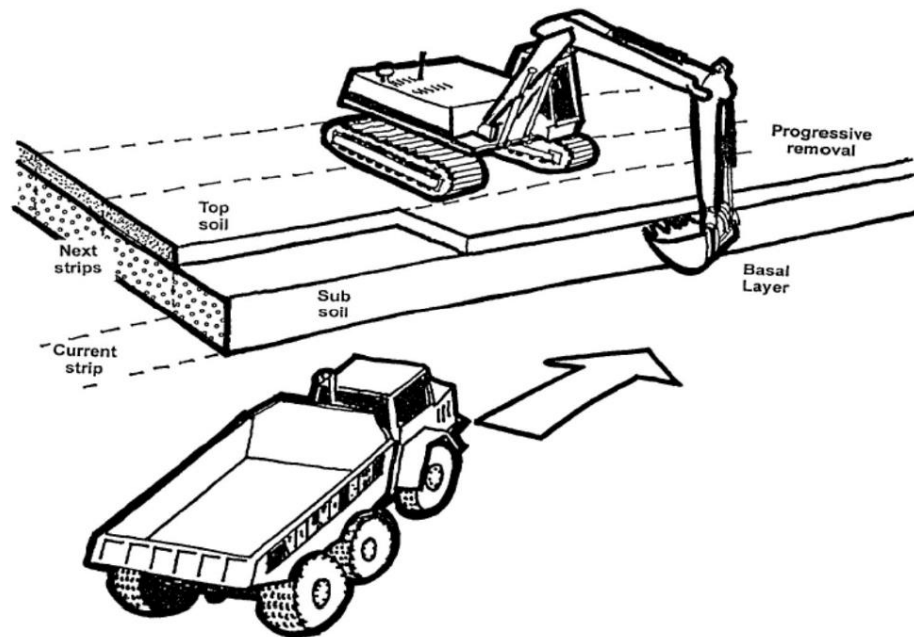

Graphic 1.2 -Stripping with excavators and dump trucks: removal of subsoil from a strip.
 Reproduced from MAFF, 2000².

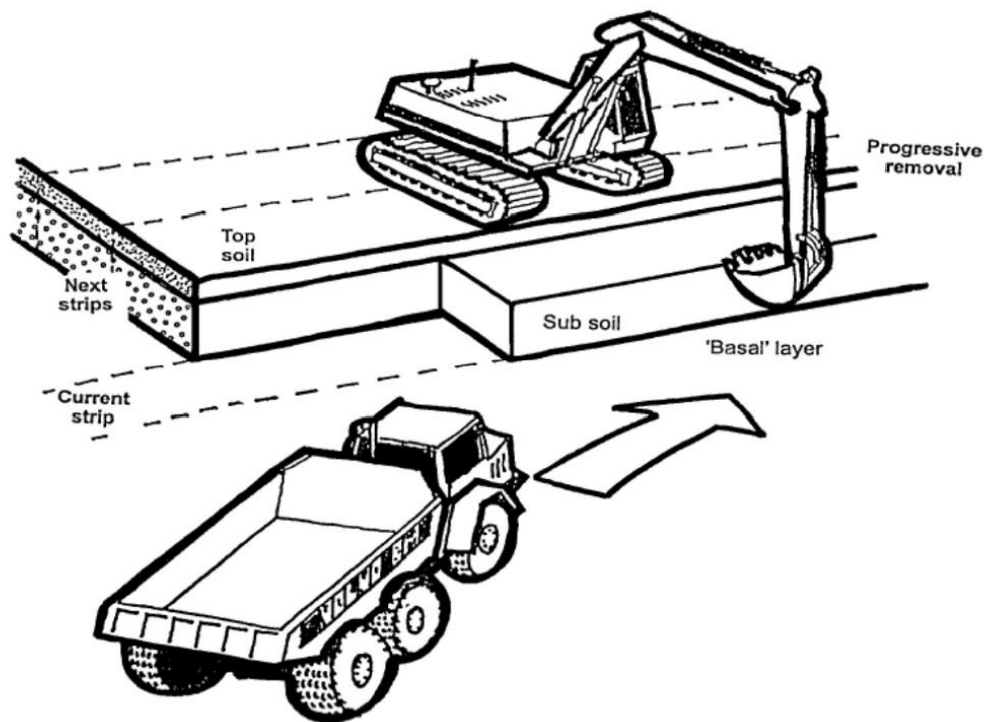

1.7.31 Prior to commencement of soil stripping, the width of each strip must be determined. Strip width is determined by the length of the excavator boom less the stand-off to operate; typically, 3 to 4 m. The strip width should make full use of the reach of the

excavator. This will maximise the time the excavator can remain at a fixed location, before moving further along the strip; minimising the number of locations subject to the weight of standing plant.

- 1.7.32 The depth of the topsoil strip is to be determined on a 'location by location' basis using the soil survey data as described in paragraph 1.7.22. During the strip, the excavator should stand on the surface of the topsoil, digging the topsoil to the required depth and forming the stockpile or loading it into the transport vehicle (dump truck). Following topsoil removal, the subsoil can be excavated (if required). Topsoil should be recovered to the full width of the strip without contamination with the subsoil. The boundary between the topsoil and subsoil is usually very clearly visible through a change in colour (the topsoil being much darker due to greater organic matter content). However, this may not always be the case, as often the topsoil gradually transitions into subsoil, and their colours are similar. Therefore, the **depth of the topsoil to be stripped must be determined by measuring the depth from the surface** (excluding any vegetation) using the detailed soil survey data as described above.
- 1.7.33 The key points to minimise soil compaction and maximise its readiness for reuse are:
- the operations of the vehicles (excavators and dumper trucks, if relevant) on the topsoil should be minimised;
 - plant and machinery are to only work when ground conditions enable their maximum efficiency, to be determined by the Site Forman;
 - soils should only be handled when dry (i.e., when tests set out in **Table 1.1** and **Table 1.2** are passed);
 - stop conditions as set out from paragraph 1.7.5 must be observed;
 - protect the subsoil from ponding of water by diverting water inflow away from it; and
 - **do not** work when there is standing water on the topsoil or subsoil surface.

Creation of soil stockpiles

- 1.7.34 Correct storage/stockpiling will maintain soil quality and minimise damage to soil structure and soil biota. This ensures that the soil will readily recover once re-spread, promoting timely and effective restoration. Stockpiled soil must not be vulnerable to compaction or erosion; must not cause pollution to surrounding watercourses; and must not increase flood risk to the surrounding area.
- 1.7.35 Potential soil erosion and water pollution can be minimised through a number of good practice measures, including, but not limited to; the avoidance of trafficking over/driving on the soil stockpiles, the seeding of stockpiles; and the use of intermittent spaces in the stockpiles.
- 1.7.36 Soil should not be stacked closer than 5 m from a watercourse or ditch. Gaps shall be left where necessary to allow for surface water drainage and avoid the catchment (ponding) of water behind stockpiles. If storing soils near to hedges or hedgerows that require maintenance, the ALO should be consulted on a sufficient track width for agricultural machinery and vehicles to undertake the maintenance, e.g. hedge cutting. Soil should not be stored in the root protection zone of trees.
- 1.7.37 Ecologically important soils, for example woodland or hedgerow soils, must be stripped and stored separately to ensure the seedbank is retained and not mixed with neighbouring agricultural soils. These stockpiles must be appropriately marked out and

clearly signed to ensure that they are easily identifiable at restoration, as specified in the location-specific construction method statements.

- 1.7.38 Generally, topsoil stockpiles should not exceed 3m in height and subsoil stockpiles should not exceed 5m in height. However, if the soil to be stockpiled is dry (below the plastic limit) formation of higher stockpiles may be permissible, if required, as the soil is likely to remain dry in the core of the stockpile for the entire storage period. However, the appropriateness of higher stockpiles will need to be established on a location-by-location basis.
- 1.7.39 Stockpiles are to be formed by 'loose-tipping' followed by 'shaping' to form a level surface on top of the pile and uniform gradients down the sides. During 'forming', the top and sides should be smoothed so that they can shed water, ensuring that the entry of the water to the stockpile is limited and that the stored soil remains dry; and helping prevent erosion and ponding. This is achieved by dragging the bottom of the excavator bucket along the stockpile surface.
- 1.7.40 The natural angle of repose of a soil, and hence the maximum gradient (slope) of the stockpile sides, depends upon its texture and moisture content. The maximum achievable slope angle is 40° however, shallower angles are often more appropriate. Where soil bunds are likely to be *in situ* for a long period (usually greater than six months) they should be seeded and maintained and a maximum slope of 25° (1 in 2) is considered appropriate, however this will be defined in location-specific construction method statements. Where soil bunds are to be *in situ* temporarily or short term, usually less than six months, they may not require seeding. However, weather conditions and soil sensitivity to erosion and should be considered, and appropriate measures put in place to reduce soil erosion where necessary.
- 1.7.41 The topsoil and subsoil stockpiles along cable trenches are to be formed using one backacting/360° excavator as they will be too close to the excavation to require transport in a separate vehicle.
- 1.7.42 If transport is required, follow the method described in the IoQ Guide, Sheet B: Building Soil Storage Mounds with Excavators and Dump Trucks illustrated in **Graphic 1.3**. A dump truck should transfer soil material between the stripping and storage areas. The dump truck should enter the storage area, reverse and back-tip the soil load starting at the furthest end of the stockpile (see **Graphic 1.3**). Repeat the process of tipping the soil against the forming stockpile and without the wheels traversing onto previously tipped material. For this operation, a second back-acting/360° excavator will be required with the boom reach allowing it to form a stockpile of up to 4 m while standing on it. Use of a front-loading machine to form the stockpile is possible if this is a Contractor's preference. If this alternative is chosen; the tipped soil must not be travelled or pushed with a bulldozer blade. It must be lifted by the front-loading machine and tipped into place to form a desired stockpile height. The top and side surfaces of the stockpile must be formed so as to shed the rainwater.

Graphic 1.3 - Soil storage mound construction with excavators and dump trucks.
Reproduced from MAFF, 2000².

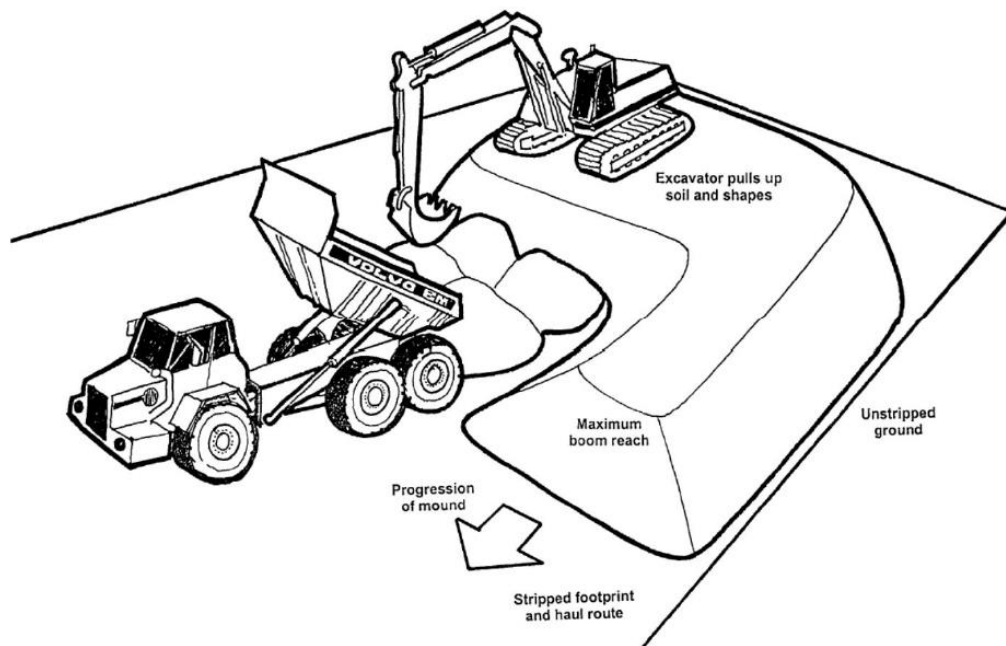

Access along cable trenches

1.7.43 Where access is necessary along cable trenches, suitable soil preparation to create a stable working area for temporary haul roads while minimising soil degradation should be undertaken. This may include measures such as soil stabilisation, soil stripping and temporary trackways being created. The subsoil may in some instances be used as the surface of temporary haul roads within the proposed cable working area. Pre-construction soil surveys should inform the subsoil bearing capacity on a location-by-location basis. Whilst it is likely subsoils along the cable route will have a moderate to high bearing capacity, 'bog mats' or stone tracks may be required where the subsoil bearing capacity is not sufficient to support the construction vehicles.

Stockpile Maintenance

1.7.44 Where soil will be stored for a period of more than six months, the stockpiles should be seeded with appropriate low maintenance grass/clover mixture (for example EG22c Emorsgate Seed, or similar) to be agreed with landowner and subject to the conditions/restrictions within the contract; to protect the soil against erosion, minimise soil nutrient loss, and maintain soil biological activity. Appropriate seeding will also help prevent colonisation of the stockpile by nuisance weeds that could spread seed onto adjacent land.

1.7.45 In the period where vegetative cover on the stockpiles is establishing, where required during dry weather, the stockpiles will be sprayed with water to prevent wind erosion (generation of dust) and to ensure that the seeds establish.

1.7.46 The stockpile vegetation cover is to be managed (by spraying, mowing or stripping as appropriate and as defined in location-specific construction method statements, or similar), to prevent the spread of seeds from the stockpile onto adjacent land.

1.7.47 Where soil will be stored for a shorter period than six months, they may not require seeding. However, weather conditions and soil sensitivity to erosion and should be

considered, and appropriate measures put in place to reduce soil erosion where necessary.

- 1.7.48 The condition of all stockpiles is to be regularly monitored. If rainwater gathers on the stockpile surface or in areas directly adjacent to them, drainage pathways to soakaway areas away from the stockpile should be provided.

Stockpile Records

- 1.7.49 The locations and footprints of each stockpile should be accurately recorded on a plan of appropriate scale. Marker post should be provided in locations which have been surveyed and recorded.
- 1.7.50 The approximate volume of each stockpile should be recorded, along with details of the type of soil stored.
- 1.7.51 Regular inspections of the stockpiled soils should be undertaken, particularly of soils that are highly sensitive and at a greater risk of erosion. If signs of erosion are observed then reforming the sides of the stockpile or implementing additional mitigation measures may be required, see **Section 1.10**.

Drainage

- 1.7.52 Prior to soil stripping, where required, pre-construction drainage will be installed as per the specification provided by a specialist drainage contractor. This drainage is designed to prevent water entering the working area.
- 1.7.53 Gaps shall be left between soil stockpiles where necessary to allow for surface water drainage and avoid the catchment (ponding) of water behind stockpiles. In certain areas (as defined in location-specific construction method statements or similar) 'grips' may be dug across the working area at predetermined locations to prevent erosion and prevent ponding against stockpiles. Appropriate measures such as stones, silt traps and silt fencing should be employed as required.

Restoration

- 1.7.54 Most of the land disturbed as a consequence of the Project will be reinstated to its original land use; however, it is noted that some areas will be restored to a different land use (for example landscaped areas adjacent to Overton and Monk Fryston Substations). In most locations, direct excavation of the soil from the stockpiles using a long-reach backacting/360° excavator will be possible.
- 1.7.55 Where larger stockpiles are created and there is a necessity for soils to be transported to the reinstatement area via dump truck, for example at the proposed substation sites or at the Temporary Construction Compounds (TCC), stockpile excavation is to follow the methodology described in IoQ Guide, Sheet C: Excavation of Soil Storage Mounds with Excavators and Dump Trucks³. In this method, the dump trucks enter the storage area travelling on the base layer (where topsoil and subsoil stripped) and on the subsoil (where only topsoil stripped). If back-acting/360° excavator is used it must stand on top of the stockpile to load the dump truck (see **Graphic 1.4**). The stockpile is dug to the base (the original subsoil) before moving progressively back along its axis.
- 1.7.56 The main objective for the restoration of agricultural land is to reinstate the land to its original (pre-development) Agricultural Land Classification (ALC) grade, and 'condition' to the reasonable satisfaction of the land owner, by reference to pre-entry record of condition (in cases where possession is returned to 3rd party PILs). This is primarily

achieved by ensuring that the full soil profile is restored in the correct sequence of horizons, and in a state where good soil profile drainage and plant root development are achieved; and by ensuring that the reinstatement works cause minimum damage to soil structure.

1.7.57 Therefore, soil restoration has been designed to achieve soil profiles as close to the original (preconstruction) as possible, which is a pre-requisite for the maintenance of the original agricultural land quality/other prior land use.

Graphic 1.4 - Excavation of soil storage mound with excavators and dump trucks. Reproduced from MAFF, 2000².

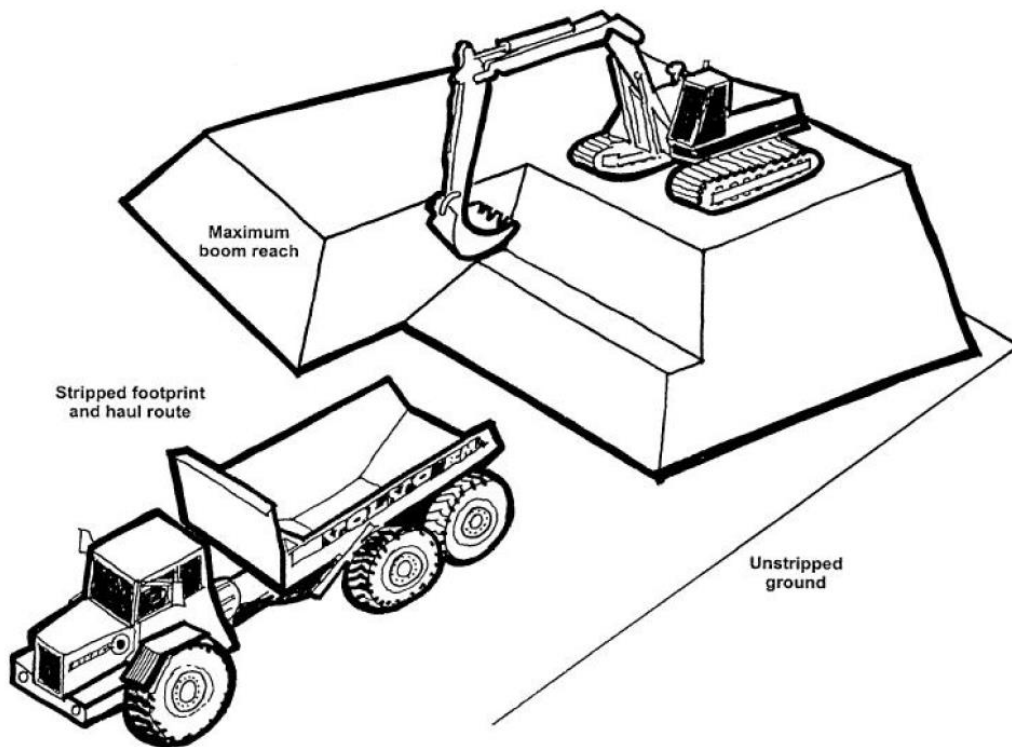

General methods to be used during restoration

1.7.58 Soil reinstatement shall be subject to the same constraints of weather and soil moisture conditions as soil stripping (see from paragraph 1.7.26 above). All methods must adhere to the general principles set out below.

Excavation of soil stockpiles

1.7.59 The size of the earthmoving plant to be used should be tailored to the size of the area to be reinstated. Front loading machines may be used, in which case they will not need to enter the top of the stockpile. Any exposed edges/surfaces should be shaped at the onset of rain and at the end of each day (see from paragraph 1.7.34).

Placement of excavated materials

1.7.60 Where restoration involves the replacement of excavated materials other than soils (i.e. material (overburden) from a depth greater than the base of the subsoil); the overburden must be replaced first. The overburden material may be overfilled by 10 to 15% to allow for settlement to the design profile, except for at the pylon footings where the overburden will be placed in layers and compacted to ensure a secure base.

- 1.7.61 Following the placement of overburden to form the base layer, where required, the surface should be graded to the required landform and any debris removed before soils are reinstated. Similarly, where required, the surface of the overburden should be loosened to an appropriate depth of not greater than 1.2 m, except for the pylon bases which will remain compacted to ensure a secure base.

Soil reinstatement

- 1.7.62 Soil reinstatement is the reverse of soil stripping with topsoil being replaced over subsoil. The specifications for reinstated soil profiles are to be determined on a location-by-location basis using the soil survey data as described in paragraph 1.7.26; and set out in location-specific construction method statements. Care must be taken to ensure that soil horizons are replaced to the correct thickness (with an allowance of up to 20% to allow for settlement).
- 1.7.63 In most locations, direct excavation and restoration of the soil from the stockpiles using a long-reach back-acting/360° excavator will be possible. In this method, the subsoil will be replaced first, with the excavator travelling on the subsoil and gradually taking the topsoil from the stockpile and depositing it on the subsoil. The deposition is to be carried out by loose tipping and a toothed digger bucket is to be used.
- 1.7.64 Soil replacement is to follow the methodology set out in IoQ Guide, Sheet D: Soil Replacement with Excavators and Dump Trucks³. In this method, the soil is replaced in strips above the base layer to recreate the original soil profile. The topsoil is replaced on the previously decompacted subsoil. The replacement is carried out in strips in a similar manner to the stripping operations. First, the initial strip width and axis is to be demarcated. The width of the strip is determined by excavator boom length less the stand-off to operate; typically, 5 to 8 m. A wide bladed bucket should be used to spread the soil (use of a toothed bucket must be avoided in this case).
- 1.7.65 The dump truck should reverse to the edge of the current strip and tip the lowest layer, without the wheels riding onto the strip. The dump truck **should not** drive away until all the soil is deposited within the strip without spillage over the basal layer. To achieve this, assistance from the excavator to 'dig away' some of the tipped soil may be required. The tipped soil should be spread to the full thickness required, by the excavator utilising the digging, pushing and pulling action of the bucket. Each load must be spread before another is tipped. The process should be repeated along the strip until it is completely covered with the required depth of the soil layer. If the spread soil comprises of large blocks (greater than 0.3 m), it should be broken down by 'slicing' them with the excavator bucket.

Soil decompaction

- 1.7.66 Due to the use of subsoil as the working surface during the cable placement, subsoil decompaction will be required prior to the placement of the topsoil. The method using a low ground pressure bulldozer either fitted or towed with winged subsoiler tines is recommended. For the decompaction to be effective, the moisture content of the soil must be below the lower plastic limit, so that the soil is dry enough to shatter and for fissures to be created. As the soil in the trench is to be deposited through loose tipping (see earlier section), no ripping of the trench area will be required. Further information on the issues surrounding soil compaction can be found in the IoQ Guide: Supplementary Note 3 – Compaction³.

Achieving the restoration standard

- 1.7.67 The quality of the soil reinstatement will need to be verified by the ALO/Land Officer or TSA as described in paragraph 1.3.8. Post-restoration surveys will be required across all land reinstated to agriculture, to determine whether target soil profile specifications have been met. The aftercare will commence after soil characteristics achieve the restoration standard.
- 1.7.68 The appointed Contractor or National Grid will commission post-construction soil surveys to record the 'after' statement of physical characteristics of the restored soils.
- 1.7.69 This 'after' statement will be compared to the 'before' statement to verify that the land has been restored to the required standard. If the restored soil properties are found to differ from the 'before' characteristics to an extent that makes it impossible for the standard to be reached, the remediation will need to be carried out before the aftercare commences. This approach will ensure that any problems are identified and rectified early after construction. This will in turn minimise the period of aftercare and risk of compensation claims.
- 1.7.70 It is noted that the physical conditions on restored land may take several years to stabilise; therefore, ALC survey is not normally undertaken (the land is not normally graded) until the end of the statutory aftercare period, or otherwise not until five-years after soil replacement⁸. Therefore, further ALC survey may be required at the end of the aftercare period.

Aftercare

Responsibilities and content of the aftercare

- 1.7.71 The aftercare will be the responsibility of the Contractor, it will include treatments such as: cultivation (e.g. subsoiling), installation of underdrainage, seeding, liming and fertilising, as and when required. The aftercare programme is to be agreed between the Contractor, landowner, and (if applicable) tenant farmer. The restoration should also be guided by pre-entry RoC, and to the reasonable satisfaction of the landowner. It will clearly define who is responsible for which part of the programme. For example, the Contractor may be responsible for initial soil testing (to determine lime and fertiliser requirements) and installation of drainage, the tenant farmer may be responsible for carrying out the cultivation and fertilisation.

Period of the aftercare

- 1.7.72 Due to the chance of differential settlement, a flexible period of aftercare of minimum one year is suggested, with the aftercare deemed complete when the restoration standard has been achieved. It will be the responsibility of the ALO to determine when the restoration standard has been met.

1.8 Biosecurity

- 1.8.1 During large-scale projects, there is the potential for disease and pathogen transfer between different areas of agricultural land (i.e. a biosecurity risk). The loss of soil

⁸ MAFF (1988) 'Agricultural Land Classification of England and Wales: Revised guidelines and criteria for grading the quality of agricultural land'. MAFF; London.

resource is considered as the main cause of disease and pathogen transfer, due to the transfer of soil from infected to uninfected areas.

- 1.8.2 To minimise the biosecurity risk, including the potential transfer of disease, pathogens and weeds, the use of best practice measures, such as the good practice guidelines set out in paragraph 1.7, will minimise soil loss and soil movement through erosion, excess trafficking on plant wheels, or unauthorised export, for example.
- 1.8.3 In addition, appropriate cleaning and/or disinfection of machinery, equipment, clothing and footwear should be undertaken between land holdings to mitigate against any disease outbreak or transfer of weeds and invasive species between holdings (refer to the **Biodiversity Mitigation Strategy (Volume 5, Document 5.3.3D)** for measures that will be implemented with regards to the management of invasive species). This will be particularly important for intensive pig and poultry units, cattle and any land with organic designations. There should be no movement of soil between land holdings where practicable, especially in areas where invasive species have been identified.
- 1.8.4 Identified invasive species should be dealt with in accordance with the law and an invasive species management plan.
- 1.8.5 The appointed Contractor will check the UK Government's website⁹ advertising current occurrences and imposed restrictions with regards to animal and plant diseases, both pre-construction and at regular intervals throughout construction. All restrictions will be adhered to and may include additional biosecurity measures being implemented such as restricted movements within prevention zones and additional measures around the disinfection of plant and equipment.

1.9 Ground Protection

- 1.9.1 The Project comprises mainly upgrading and installing new towers and overhead lines within the Order Limits. The majority of this work will be able to take place without substantial stripping and long-term storage of soils, by utilising ground protective matting and trackways.
- 1.9.2 All vehicular movement should be restricted to designated areas (as described in the site-specific management plan) or be low ground pressure. Designated areas include but are not limited to construction compounds, ground protective matting, stone trackways, haul roads, and existing trackways.
- 1.9.3 Specific measures for ground protective matting and stone trackways are described below.

Ground Protective Matting

- 1.9.4 Ground protective matting can be used to provide a temporary road surface but is only suitable for temporary use and should be trafficked lightly.
- 1.9.5 If there is to be heavy trafficking or heavy machinery that is not low ground pressure, the topsoil should be stripped and the ground protective matting placed on top of the subsoil.

⁹ Defra (2022) Animal and Plant Health Agency. (Online) <https://www.gov.uk/government/organisations/animal-and-plant-health-agency> (Accessed July 2022)

- 1.9.6 Where possible all traffic should be low ground pressure.
- 1.9.7 It is important to note that when the soil wet and in a plastic state (such as in the winter), heavy trafficking of ground protective matting can cause the matting to sink and the soil to plume at the sides. This causes the mixing of topsoil and subsoil and reduces soil quality.

Stone Trackways

- 1.9.8 For long term or more substantial trackways the topsoil should be stripped, a geotextile laid on the subsoil surface and stones be laid on top of the geotextile to ensure no mixing of soil and stones occurs.
- 1.9.9 Where temporary stone trackways are used, the reinstatement of the soil resources should be done in accordance with the stripping and reinstatement described in paragraph 1.7.

1.10 Bespoke Mitigation Measures

Monitoring Schedule

Soil Handling and Storage Monitoring Protocol

- 1.10.1 **Table 1.3** summarises the need for record keeping and monitoring during the construction phase.

Table 1.3 - Record keeping and monitoring during the construction phase.

Item	What to look for	Responsibility	Frequency
Soil stockpiles.	Erosion rills, water ponding, loss of protective vegetation or/and geotextile cover, invasive weeds	Contractor	Once a month and after rainfall exceeding 10 mm in 24 hrs.
Soil handling.	Conformance with the SMP, record operations undertaken, weather and soil conditions, any problems and corrective actions undertaken.	Contractor	Daily.
	Conformance with the SMP, check daily record.	ALO/Land officer	Varies, but at least once a week.
Verification of the restoration standard.	Has the soil profile been restored to, as much as practicable to do so, a condition when last used for agriculture?	ALO/Land officer	Once, after reinstatement, re-inspected after remediation (if applicable).
Aftercare reports.	Significant differences in crop performance, compaction and waterlogging between the restored and undisturbed land.	Land officer	Annually until unrestricted agricultural use can commence.

- 1.10.2 It is expected that annual reports will be required during the aftercare period. The aftercare report will contain results of appropriate soil testing, the TSA will determine what tests are required and carry out the testing and record the soil condition. As a minimum the testing will comprise:
- visual assessment of plant cover and ground surface; and
 - a series of trial pits to assess the soil structure at depth and penetration by plant roots.
- 1.10.3 Non-conformance reporting, corrective actions, and incident responses are to be undertaken by the ALO according to the procedures described in the **CoCP, Document 5.3.3B**.

Management of surplus soils

- 1.10.4 The construction of new permanent infrastructure, such as the new substations will create a volume of surplus topsoil and subsoil. To minimise the loss and degradation of soil resources the management options for surplus soils will be undertaken in the following order of preference where practicable:
- The creation of permanent visual bunds.
 - Retain for reuse elsewhere within the Project if additional soil is required for restoration purposes.
 - Increase topsoil depths (by <5cm, assuming topsoil depths will not become much greater than 30 cm) in the substation site or nearby fields of the Project. This may require a separate licence or exemption and will require a separate method statement.
 - Export for reuse on other National Grid projects (pending testing and certification).
 - A wider search locally to identify potential areas requiring restoration, where the soil could be reused off site.
 - Soils to be banded in a suitable fashion for storage over the medium term for resale off site. This would facilitate storing and selling in batches as and when there is a demand. This would require a local topsoil trader to manage the process and land to store it on.
 - Where none of the other options are available, the soil may be recycled on site for recovery of any valuable fractions. This is likely to be what would happen if diverted to landfill.
 - Diverted to landfill.
 - It is noted that specific certification, licenses or exceptions may be required for each of the options listed above.
- 1.10.5 At the CSECs the surplus soil will be removed from the site as there is no capacity for it to be reused on site and removed to a suitable waste facility.

National Grid plc
National Grid House,
Warwick Technology Park,
Gallows Hill, Warwick.
CV34 6DA United Kingdom

Registered in England and Wales
No. 4031152